

# Hillmar

## Hillmar Industries Ltd.

7371 Vantage Way  
Delta, BC V4G 1C9  
P:604 946-7115 F:604 946-0329  
info@hillmar.com www.hillmar.com

### CABLE REEL VD DAVD GBSR DAVD-0750-GB50SD-0610KV-140 SPECIFICATION SHEET SLS & MKTG ENGLISH

Sheet Number:

Job Number:

Form Number:  
629-863-75959PT

Company / Project Reference:

Date.:

Page.:

Document Package No.: Rev.:

Inventor Drawing

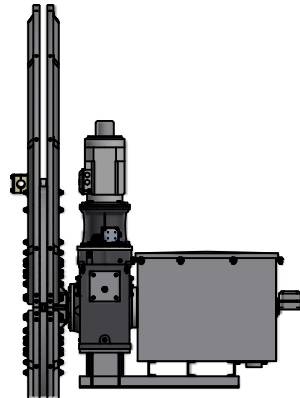

FEATURE	CODE
Drive Assy Vector Drive	DAVD
Vector Drive Motor Size	0750
Gearbox Single Drive	GB50SD
Voltage	0610KV
Fiber Optic	Not available
Vector Drive Torque Nm	140

<b>Example for ordering</b>	DAVD-0750-GB50SD-0610KV-140
-----------------------------	-----------------------------

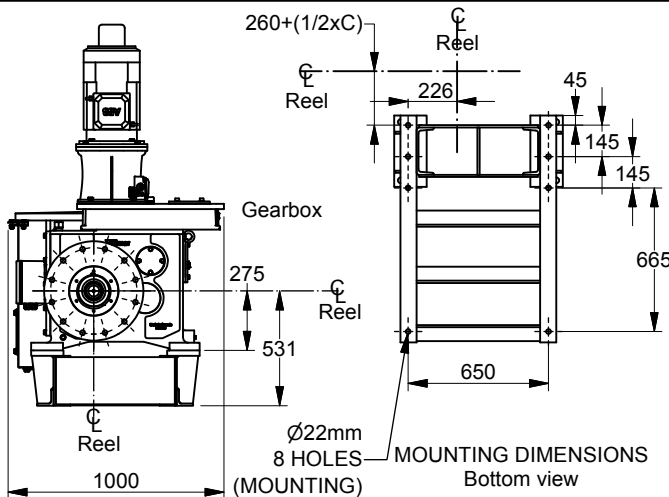

#### TECHNICAL DATA

Motor Size	7.5 kW
Spool Sizes Available	4.0m to 8.5m
Gearbox Hollow Shaft	90mm
Gearbox Drive Torque Nm	8000
Gearbox Max Overhang Load	75kN
Slipping Enclosure Design	06-10KV
Rotary Switch Ratio	RS
Drive Weight Excluding Spool	800kg
Spool Weight	Contract Specific
Mounting Holes	8 x Ø22
Mounting Bolts	8 x M20 GR10.9
Slipping Enclosure	SS304

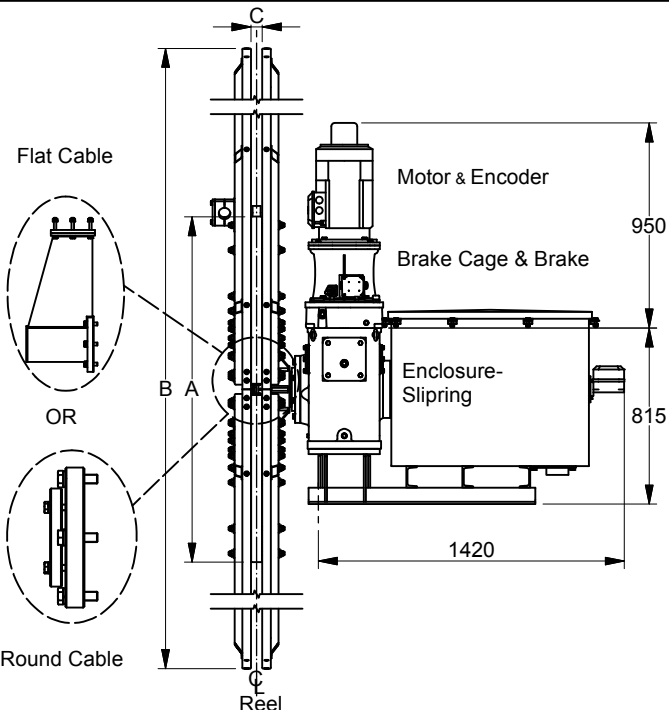

#### NOTES

For Other Reel Types refer to one of the following sections:

- Flat Cable Reel
- Hose Reel
- Control Reel
- Vector drive Reel

Document Template #710-101-62058

\*\* ALL TECHNICAL DATA IS SUBJECT TO CHANGE WITHOUT NOTICE \*\*

Hillmar works have a fully registered ISO 9001-2008 quality assurance programme (QCB #01-1525)

**Storm Brakes • Thruster Disc Brakes • Thruster • Industrial Disc Brakes • Hydraulic Power Units • Cable Reels**

C:\TEMP\8718diff5-874f-4422-bec7-fec3dce6093080000529344\HILLMAR\HILLMAR PRODUCTION\06 CABLE REEL\CABLE REEL DAVD-0750-GB50SD-0610KV-140.icw